

A person in a cleanroom environment, wearing a white lab coat and white gloves, is working with a microscope. The person is looking through the eyepiece of the microscope. The microscope is mounted on a blue petri dish. There are other petri dishes on the table, some with blue markings. The background is a clean, white surface.

Cleanroom

**“Zero-emission chair
affords pure
sitting pleasure.”**

Cleanroom

Indispensable – Certified top-of-the-range seating for use in cleanrooms

In order to create “clean” or “sterile” rooms, measures have to be implemented to prevent products and processes from becoming contaminated. This is a key requirement of the microelectronics sector, the pharmaceuticals industry, microsystem production, optics, medical engineering and healthcare. That is why bimos has worked together with industry and research specialists to develop its innovative range of cleanroom chairs for use in extreme conditions.

We put our claims regarding the quality of these chairs to the test on a daily basis by subjecting them to a comprehensive series of tests that prove the low level of particle emissions and the reliability of the electrostatic discharge measures used. This quality is also borne out by empirical evidence arising from day-to-day use.

bimos cleanroom chairs boast astounding properties and meet the requirements of air cleanliness classification 3 in accordance with DIN EN ISO 14644-1, cleanroom classification 1 as defined by US Federal Standard 209E and the specifications of the EU GMP guidelines.

It is the sophisticated design coupled with the perfect implementation of that design that make bimos cleanroom chairs top of their game.

bimos ensures the following in respect of all its cleanroom chairs:

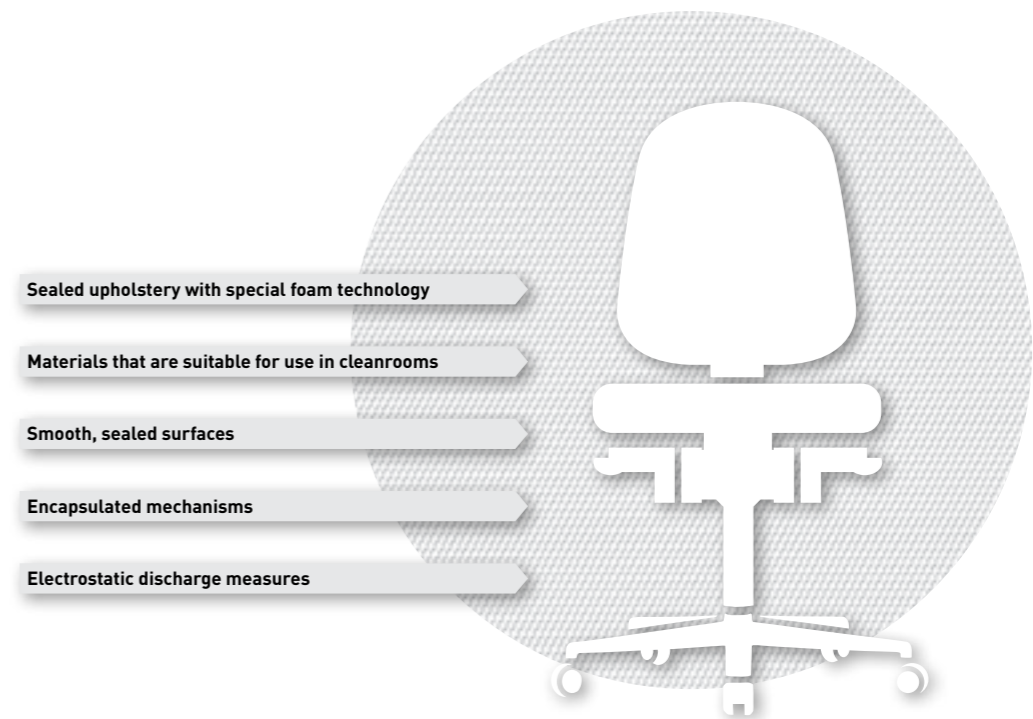

bimos	Air cleanliness classification to:			Particle size and permissible number of particles per cubic metre of air acc. to EN ISO 14644-1				
	EN ISO 14644-1	EU GMP guidelines	US Fed St. 209E	≥ 0,1 µm	≥ 0,2 µm	≥ 0,3 µm	≥ 0,5 µm	≥ 1,0 µm
1	–	–	–	10	2	–	–	–
2	–	–	–	100	24	10	4	–
3	–	–	1	1000	237	102	35	8
4	–	–	10	10.000	2.370	1.020	352	83
5	–	A/B	100	100.000	23.700	10.200	3.520	832
6	–	–	1000	1.000.000	237.000	102.000	35.2000	8.320
7	–	C	10.000	–	–	–	352.0000	83.200
8	–	D	100.000	–	–	–	3.520.000	832.000

There are various definitions of cleanrooms, depending on the precise nature of the application and sector concerned. The table above provides an overview of various standards and how these relate to the bimos classifications.

Cleanroom Plus

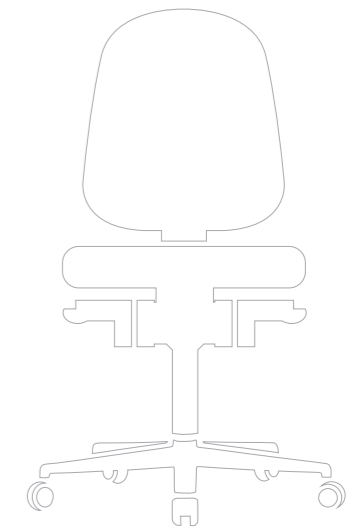

Cleanroom

The high-comfort solution for solid cleanroom performance

Our Cleanroom Plus chairs are the flagship of our cleanroom seating solutions. They offer excellent cleanroom properties and are equipped with a perfect electrostatic discharge system. Furthermore, these chairs cannot fail to impress with their superb ergonomic design and luxurious level of comfort. Consequently, Cleanroom Plus not only meets the technical requirements but also measures up to the expectations of those who work in cleanrooms every day.



Fraunhofer confirms the chairs' suitability for cleanrooms

The Fraunhofer IPA seal of approval certifies that Cleanroom Plus chairs are suitable for use in cleanrooms in compliance with the following standards:

- Air cleanliness classification 3 pursuant to DIN EN ISO 14644-1
- Air cleanliness classification 1 pursuant to US Fed. St. 209 E
- Provisions of the EU GMP guidelines
- Electrostatic discharge measures pursuant to EN 61340-5-1



Cleanroom properties



The smooth, sealed surfaces of the seat and backrest shells prevent swirl even when there is a constant flow of air through the filter system and stop the build-up of particles on the chair.

The synthetic leather, upholstery and upholstery support are permanently bonded using special foam technology to ensure that no particles can be emitted.

The sealed design of the seat and backrest cover means that all the moving parts of the chair's mechanical system are enclosed so that particles cannot escape.

All bimos cleanroom chairs feature electrostatic discharge measures in accordance with EN 61340-5-1 and offer reliable antistatic protection.

The chairs are supplied with a brilliantly polished and abrasion-resistant aluminium 5 star base. The seat support and backrest cover are both made from sheet steel, making them sturdy and durable.

Cleanroom Plus



Design and materials

On Cleanroom Plus, the seat and backrest shells are made from sheet steel and provide optimum protection against particle emissions. The metal components have a conductive coating and the plastic components are volume conductive. These components are all light grey. The synthetic leather cover, which is also conductive, has non-slip properties and ensures a firm grip even when the user is wearing smooth cleanroom clothing.

Mechanisms and functions (for precise details, see pages 16-17)

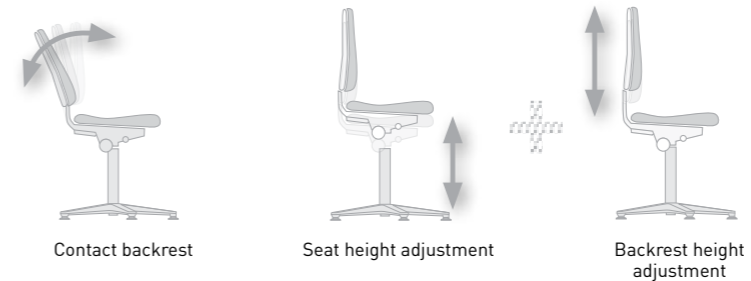

Options



Mushroom glides

Steel disc glides

Seat height adjustment range: 480 to 640 mm

Accessories (for precise details, see page 141)



Ring-shaped armrest

Foot ring

Upholstery finish and colour options

Finish **Black**

Skai ESD synthetic leather



Order no. 2571



Cleanroom Plus 2 Height of backrest: 380 mm

Seat height adjustment range: 440 to 565 mm.
Option: 480 - 640 mm.

Design	Order no.
Contact backrest	9181-2571



Cleanroom Plus 2 Height of backrest: 500 mm

Seat height adjustment range: 440 to 565 mm.
Option: 480 - 640 mm.

Design	Order no.
Contact backrest	9161-2571



Cleanroom Plus 3 Height of backrest: 380 mm

Seat height adjustment range: 630 to 890 mm.

Design	Order no.
Contact backrest	9183-2571

Cleanroom Basic

The tried-and-tested all-rounder for use in cleanrooms

An ergonomic design, superb cleanroom properties and reliable ESD measures are a lot to ask from a workplace chair. Yet Cleanroom Basic meets all these criteria and offers a high level of quality in the process. The fact that the chairs have to pass a comprehensive series of tests before they are awarded a test certificate and prove themselves in extreme working environments means that our claims of quality are not just empty words.

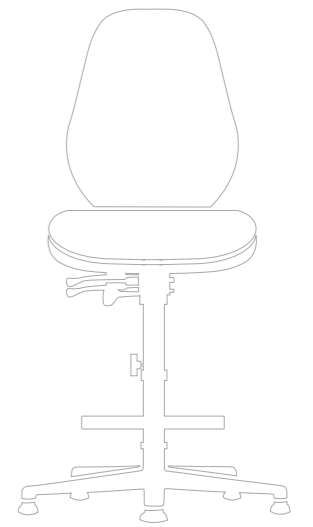

Fraunhofer confirms the chairs' suitability for cleanrooms

The Fraunhofer IPA seal of approval certifies that Cleanroom Basic chairs are suitable for use in cleanrooms in compliance with the following standards:

- Air cleanliness classification 3 pursuant to DIN EN ISO 14644-1
- Air cleanliness classification 1 pursuant to US Fed. St. 209 E
- Provisions of the EU GMP guidelines
- Electrostatic discharge measures pursuant to EN 61340-5-1



Cleanroom properties



The smooth, sealed surfaces of the seat and backrest shells prevent swirl even when there is a constant flow of air through the filter system and stop the build-up of particles on the chair.

The synthetic leather, upholstery and upholstery support are permanently bonded using special foam technology to ensure that no particles can be emitted.

All bimos cleanroom chairs feature electrostatic discharge measures in accordance with EN 61340-5-1 and offer reliable antistatic protection.

The chairs are supplied with a brilliantly polished and abrasion-resistant aluminium 5 star base. The seat support and backrest cover are made of plastic.

Cleanroom Basic

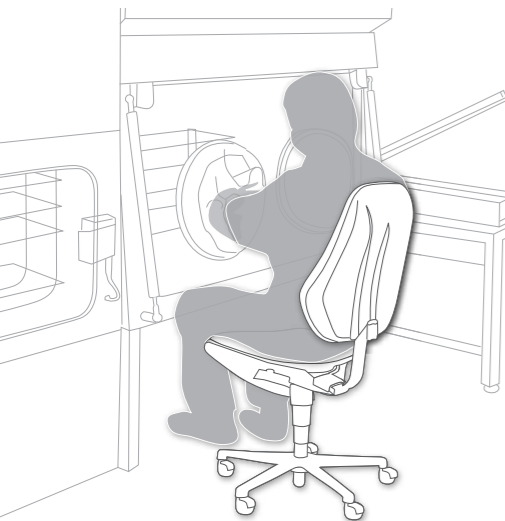

Design and materials

The base frame, which is made from die-cast aluminium, is brilliantly polished and is supplied with conductive castors/glides for hard floors. The non-tear synthetic leather cover, which is also conductive, has non-slip properties and ensures a firm grip even when the user is wearing smooth cleanroom clothing.

Mechanisms and functions (for precise details, see pages 16-17)

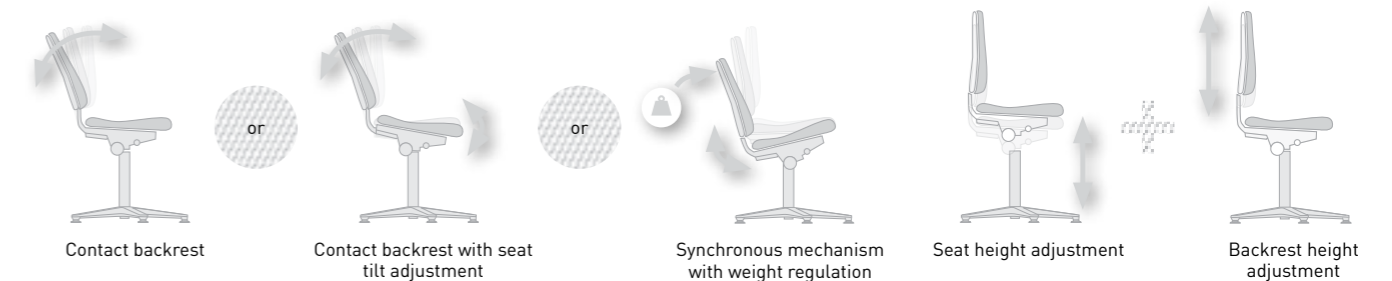

Options



Mushroom glides

Accessories (for precise details, see page 141)



Ring-shaped armrest



Multifunction armrest



Foot ring

Upholstery finish and colour options

Finish **Black**

Skai ESD synthetic leather



Order no. **2571**



Cleanroom Basic 2 with castors

Seat height adjustment range*: 470 to 610 mm.

Design	Height of backrest	Order no.
Contact backrest	430 mm	9140-2571
Contact backrest with tilting seat	530 mm	9142-2571
Synchronous mechanism with weight regulation	530 mm	9145-2571

* 20 mm increase in seat height with the synchronous mechanism.



Cleanroom Basic 3 with glides and step

Seat height adjustment range*: 620 to 870 mm.

Design	Height of backrest	Order no.
Contact backrest	430 mm	9141-2571
Contact backrest with tilting seat	530 mm	9143-2571
Synchronous mechanism with weight regulation	530 mm	9146-2571

* 20 mm increase in seat height with the synchronous mechanism.

Cleanroom Stools



Fraunhofer
TESTED®
DEVICE
Interstuhl Höcker 9468R
Report No. IN 0312-300



DIN
68877



warranty
5
years



Industrious assistants

Stools provide an ad hoc seating solution for anywhere within the cleanroom. They can also be used instead of chairs when there is a lack of space. The comprehensive range of stools completes the bimos cleanroom collection with these indispensable assistants. The base frames, which are made from die-cast aluminium, are brilliantly polished and are supplied with conductive castors/glides for hard floors. The synthetic leather cover also has conductive and non-slip properties.

Fraunhofer confirms the chairs' suitability for cleanrooms

The Fraunhofer IPA seal of approval certifies that Cleanroom Stools are suitable for use in cleanrooms in compliance with the following standards:

- Air cleanliness classification 4 pursuant to DIN EN ISO 14644-1
- Air cleanliness classification 10 pursuant to US Fed. St. 209 E
- Provisions of the EU GMP guidelines
- Electrostatic discharge measures pursuant to EN 61340-5-1

Functions (for precise details, see pages 16-17)

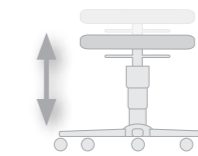

Seat height adjustment based on pneumatic spring system with easy ring control



Cleanroom Ergo Stool 1 with glides

Seat height adjustment range: 460 to 630 mm.

Design	Order no.
Skai ESD synthetic leather, black	9467R-2571



Cleanroom Stool 2 with castors

Seat height adjustment range: 460 to 630 mm.

Design	Order no.
Skai ESD synthetic leather, black	9468R-2571



Cleanroom Stool 3 with glides and foot ring

Seat height adjustment range: 570 to 850 mm.

Design	Order no.
Skai ESD synthetic leather, black	9469R-2571

Finish and colour options for seat

Finish **Black**

Skai ESD synthetic leather



Order no. 2571